

Coaxial Cable Connector 11_TNC-50-4-24/122_N

Description

Straight cable plug

Interface standards
EN4652-210-B50



Technical Data

Electrical Data

Impedance	50 Ω
Interface frequency max.	6 GHz
Frequency range	DC to 6 GHz
Return loss	23.1 dB

Mechanical Data

Centre contact	plugged
Outer contact	clamped
Weight	0.025 kg

Environmental Data

Operating temperature	-65 °C to 165 °C
2011/85/EU (RoHS - including 2015/863 and 2017/2102)	compliant

Material Data

Piece Parts	Material	Surface Plating
Centre contact	Copper Beryllium Alloy	Gold Plating (Nickel underplated)
Outer contact	Brass	Nickel Plating
Body	Brass	Nickel Plating
Other body part	Stainless Steel	Passivated (Plating)
Insulator	PTFE (Polytetrafluoroethylene)	
Coupling nut	Stainless Steel	Passivated (Plating)
Gasket	VMQ (Silicone rubber)	

Related Documents

Outline drawing	DOU-00223311
Assembly instruction	DOC-0000404480

Ordering Information

Single package	11_TNC-50-4-24/122_NE
----------------	-----------------------

Additional Information

Suitable cables	KX_EN4604-010
-----------------	---------------

Diese Zeichnung ist unser geistiges Eigentum und darf ohne unsere Einwilligung weder kopiert, vervielfältigt noch Dritten oder Konkurrenzfirmen zugänglich gemacht werden. (Art. 12 B. G.)
 This drawing is copyright. Information contained thereon is supplied in confidence and must not be used for any other purpose than which it was supplied, or be reproduced without written permission of the owners.

Cable shortening dimension

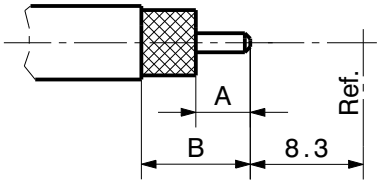

Cable	Stripping dimensions	
	A	B
EN4604-010 KX	4 ±0.4	8 ±0.4

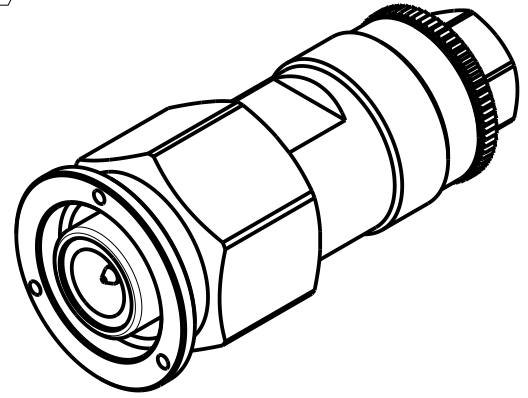
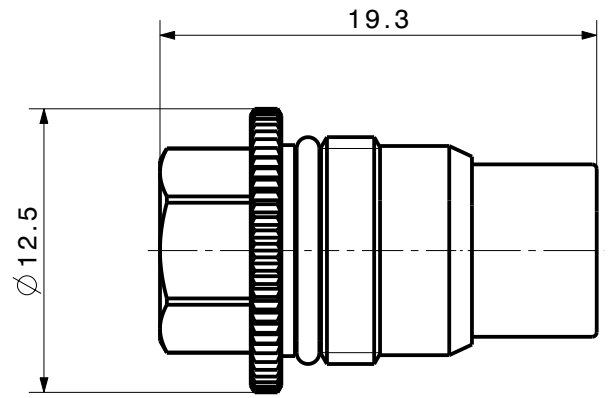
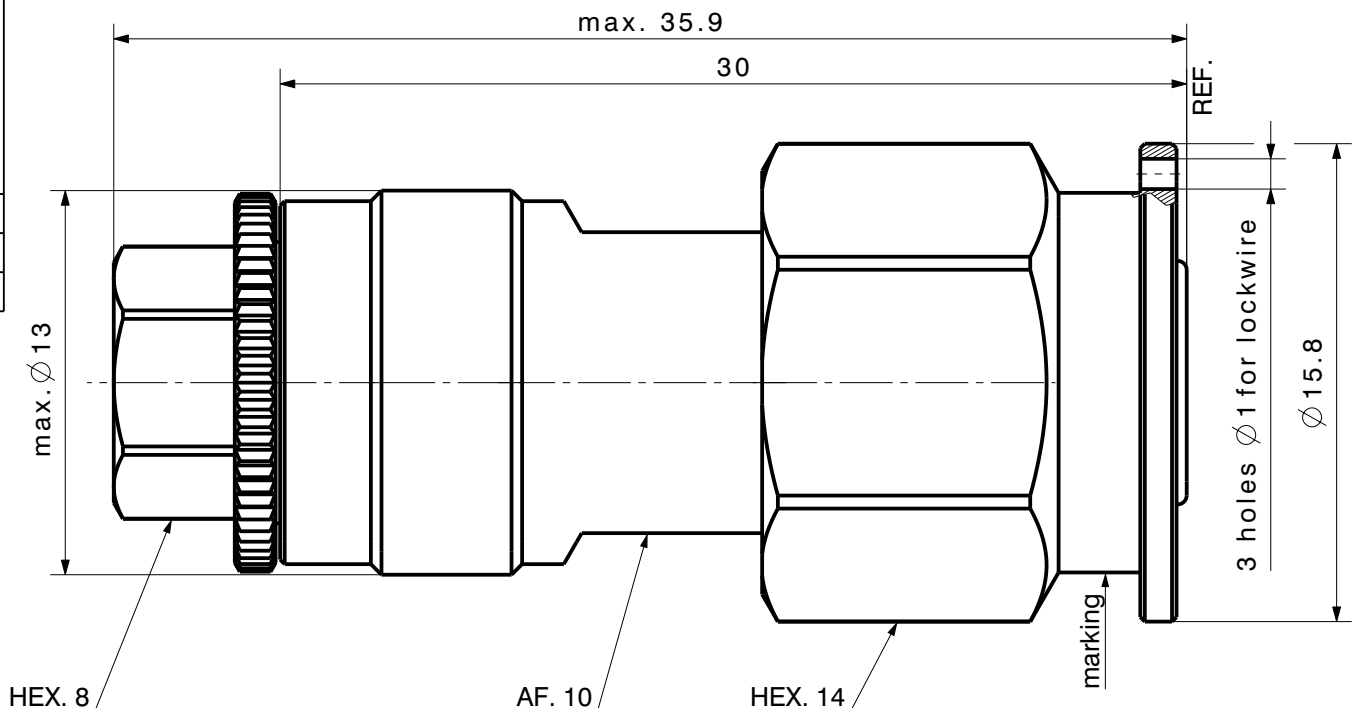

according to: EN 4652-210-B50

type / Typ: 11_TNC-50-4-24	part no. / Teile Nr.: PRO-00223311	A sheet/Blatt XX / XX
description / Beschreibung Cable plug	drawing-no. / Zeichnungsnr. DOU-00223311	Release B



alternative ID:

Assembly instruction

0000404480



Connector type:	11_BNC-50-4-34 ; 16_BNC-50-4-15 ; 25_BNC-50-4-17 ; 11_TNC-50-4-24 ; 16_TNC-50-4-102 ; 25_TNC-50-4-19 ; 21_TNC-50-4-22 ; 11_N-50-4-20 ; 16_N-50-4-15 ; 25_N-50-4-9 ; 11_C-50-4-7 ; 16_C-50-4-4 ; 25_C-50-4-5	Inner conductor contact:	Plugged
Suitable cables:	EN4604-010 KX	Outer conductor contact:	Screwed

Parts list connector:

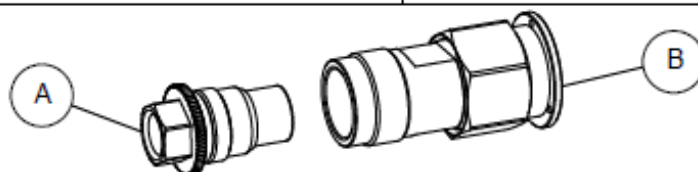

Assembly steps:

Picture	Process	Feature / Check	Tools required
	Cut cable to requested length.	Cut perpendicular to cable axis. Proper sectional area. Centre pin concentrical.	Metal saw 74_Z-0-0-12 or suitable tool
	Prepare cable according to sketch. At position X, cut in jacket until screen. Trim inner conductor.	Ensure that braid, dielectric and inner conductor of cable are undamaged. Tip of cable inner conductor must be free of burrs.	Tool CST 74_Z-0-0-473 Tip trimmer 74_Z-0-0-474
	Plug the cone X on to the inner conductor and push the body A on to the cable.	Ensure the cone covers the sectional area.	Cone 74_Z-0-0-616
	Slide shrink tube, then body A onto cable and remove jacket of the cable. Slide body A back flush to jacket X. Mark cable on jacket at Y according to sketch.	Ensure that braid is undamaged. Detect distance between marking and body A.	Marker Razor blade 74_Z-0-0-68
	Fold back braid over body A	Ensure that the whole braid lies above body A.	Brush 74_Z-0-0-476
	Loose the foil from the insulation. Unreel the foil until the folded back braid and cut off the foil flush.	Do not pull out the foil underneath braid.	Scissors Foil remover 4 mm 74_Z-0-0-474
	Clean dielectric and inner conductor of cable.	No metallic parts (e.g. burrs, wires, etc.) on inner conductor and dielectric allowed.	Brush 74_Z-0-0-476
	Push cable with body A into body B and tighten. Do not change position of body A on cable while tightening. Hold tight body B and rotate body A for tightening. Torque 4 ± 1 Nm	Ensure that distance between marking and body A is not displaced for more than 0.5 mm.	Torque wrench AF 8 mm 74_Z-0-0-475 Spanner AF 10 mm 74_Z-0-0-479
	Slide shrink tube over connector according to sketch and shrink.	Glue of the shrink tube has to ooze out slightly on both sides.	Hot-air fan

The cable assembly of R.F. connectors can only be done by well trained assembly staff and suitable assembly equipment. Huber+Suhr's skilled staff and specialised equipment are available to carry out complete R.F. lead-assembly on your behalf. We mount your connectors on cables at economic prices! Please contact our representative for further details of this service.

Revision	B
Date	15.10.2013
Initiator	4240/bua